



Proudly serving the industry with high quality hose and fitting products since 1945.

CC150MOB-110/1-NRP Mobile Application Hose Crimper



Metric Dial Micrometer



Quick Change Tool



Manual Back Stop



Available in 12VDC/24VDC

ENGINEERED TO ACCOMMODATE YOUR NEEDS

- Hose capacity up to 1-1/4" for 1 and 2 WIRE ,4SH and 100R12
- Dial Metric Micrometer makes precise settings of crimp diameters simple.
- Foot Switch permits dies to be "jogged" into position and keeps both hands free.
- Quick Change Tool makes die changes a quick and simple process.
- Manual Back Stop speeds multiple crimps of the same hose and fitting.
- Easy grease maintenance through the 8 grease fittings.
- Protective Master Die Foam Pads between the die fingers prevent debris from dropping into the critical surfaces and causing permanent damage.
- Reservoir mounting holes allow the crimper to be bench or truck bed mounted if required.
- CC150MOB series crimpers is also available in 12VDC or 24VDC for mobile applications.

DURABLE + RELIABLE DESIGN = PROFITABILITY

- 240 Tons of crimping force.
- 2HP motor wired at 220 volts single phase (Standard).
- (Multiple electrical configurations available).
- Complete range of dies and accessories available.



Proudly serving the industry with high quality hose and fitting products since 1945.

CC150MOB-110/1-NRP Mobile Application Hose Crimper



84mm Quick Change Tool
(Included) P/N:102572



Foot Pedal Assembly
(Included) P/N:104118



Manual Back Stop (Included)
P/N:MBS-60



Die Rack 9 Station Die Holders
(Included) P/N:102616-84mm



Mini Grease Gun w/ CRIMPX Die
Lubricant 3 oz mini grease tube
(Included) P/N:103889

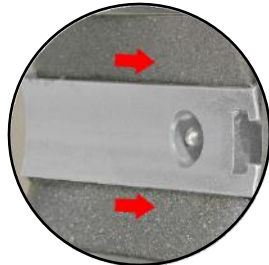

8 Protective Master Die
Foam Pads (Included)
P/N:102531 (each)



Available: CRIMPX Die Lubricant
3 oz mini grease tube P/N:103887



Available: Crimper Stand 16
Station Die Holders
P/N:101247-84

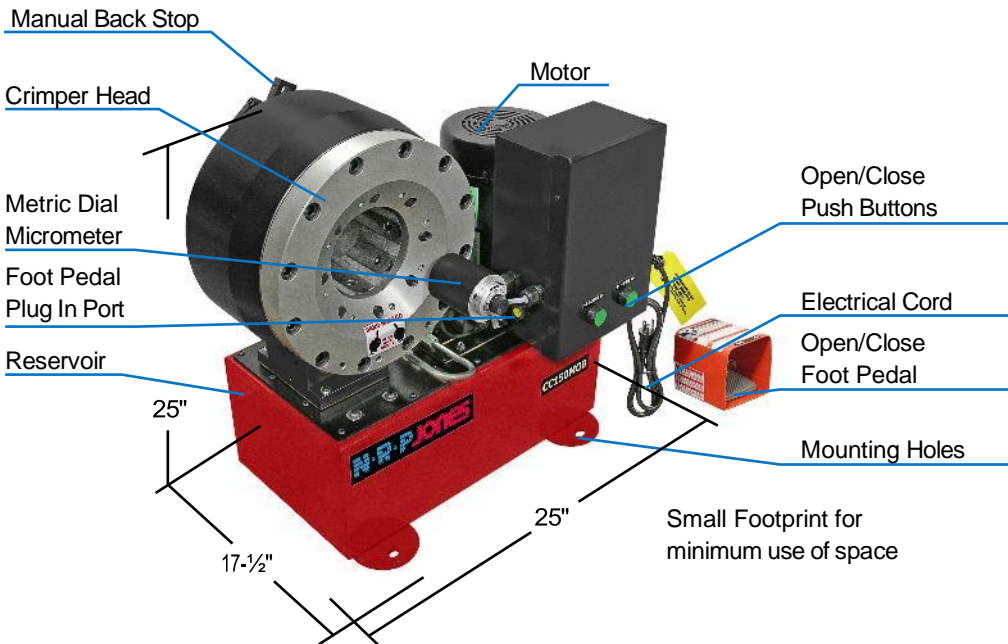

CC150MOB-110/1-NRP Technical Specifications	
Crimping Force:	240 Ton
Hose capacity up to 1-1/4" for 1 and 2 Wire ,4SH and 100R12	
Industrial Hose Capacity:	2"
Crimper Size: L: 17-1/2" x W: 25" x H: 25"	
Crimper Weight:	400 lbs
Power:	1.5HP/110V/1-Phase
Die series:	84S
Adjustability:	Metric
Opening w/o dies:	120mm / 4.72"
Master die inside diameter:	84mm / 3.31"
Master die travel:	38mm / 1.5"
Reservoir capacity:	6 Gallons
Oil type:	ISO 46 Hydraulic Oil